

ADD S

Francesco Rota | 2016



ADD S

Francesco Rota | 2016

Documenti, libri, oggetti. Memorie e sguardi al futuro. Ogni tempo della progettazione trova il suo spazio negli elementi contenitori del sistema ADD S. In linea con la libertà inventiva delle sedute, i moduli contenitori in metallo profondi 45 cm e disponibili in tre altezze si compongono con versatilità, unendosi a tavoli e formando a loro volta postazioni di lavoro. Bifrontali, con aperture a giorno o chiusi con cassetti e ante, i mobili in metallo arredano agilmente il centro stanza e le pareti. Stessa scioltezza nelle finiture e nei colori che esaltano il rigore monocromatico o giocano a contrasto con le tonalità delle sedute e dei cuscini. Un sistema di contenitori ufficio che aggiunge personalità agli ambienti di lavoro garantendo ordine e funzionalità.

Sistema di contenitori in metallo ideale per creare madie, armadiature, scaffali, librerie e composizioni dinamiche e vivaci a parete o a centro stanza



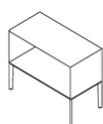

S — open

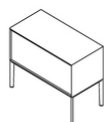

S — flap door

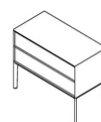

S — two drawers



M — open

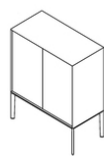

M — doors

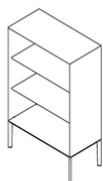

L — open

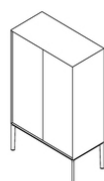

L — doors

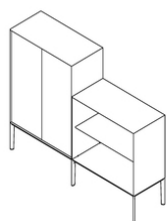

L – doors + M – open

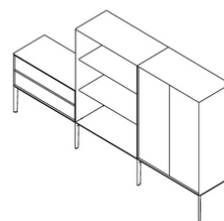

S – two drawers + L – open + L – doors

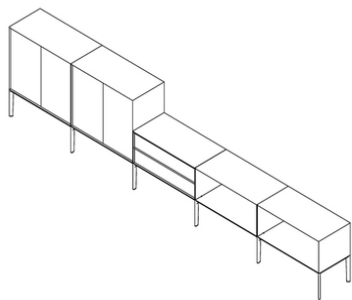

M – doors double + S – two drawers + S – open double

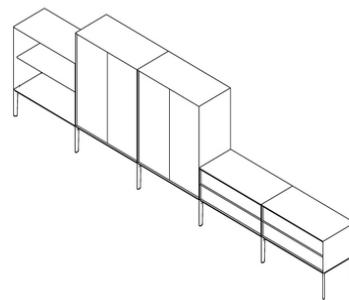

M – open + L – doors double + S – two drawers double

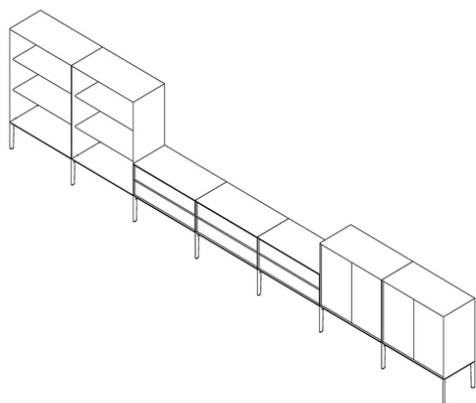

L – open double + S – two drawers triple + M – doors double

ADD S

Francesco Rota | 2016

Sistema modulare di contenitori e sedute, su telaio in alluminio estruso e gambe angolari o centrali in pressofusione. Contenitori in lamiera verniciata a polveri. Cassetti, schiene e ante in varie finiture. Piano del tavolino in HPL Fenix®. Sedute con cinghie elastiche, cuscini sfoderabili in poliuretano espanso con fibra poliestere accoppiata ignifughi, rivestiti in tessuto o ecopelle. È disponibile anche la cassettera su ruote con serratura. Il sistema di contenitori è abbinabile con il sistema di tavoli e sedute ADD.

gambe



telaio

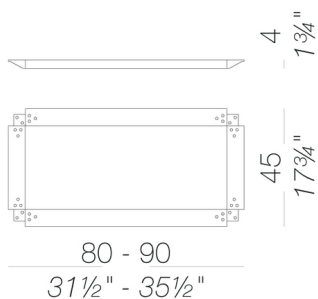

piano

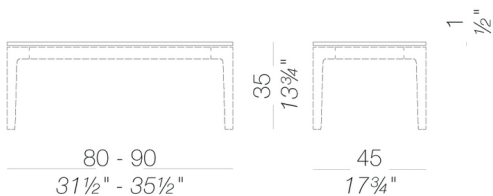

contenitori

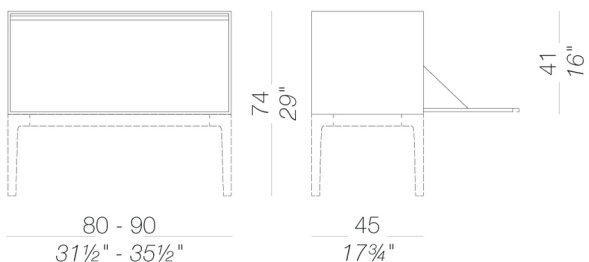
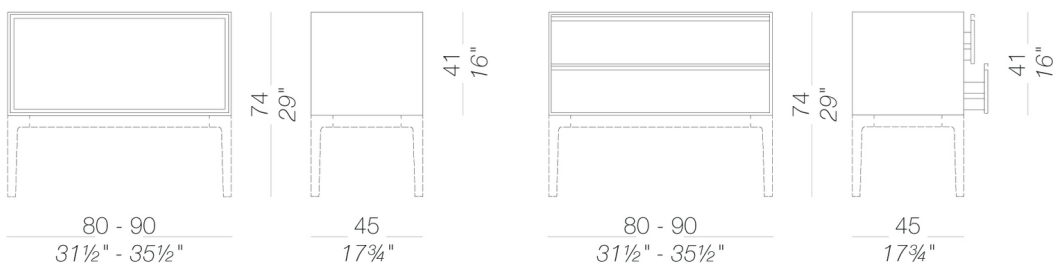

ADD S

Francesco Rota | 2016

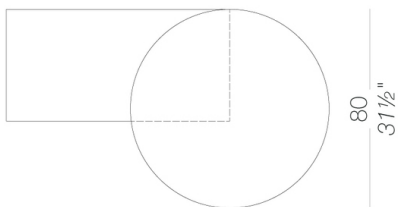
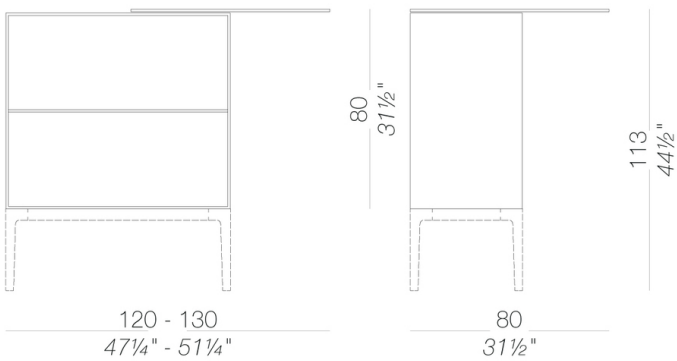
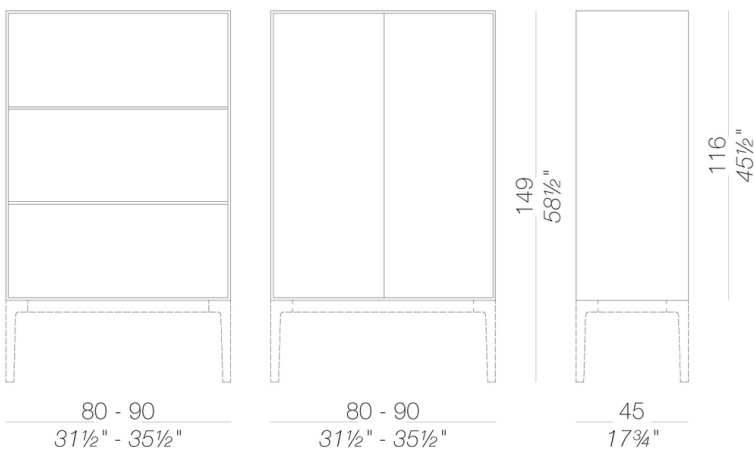
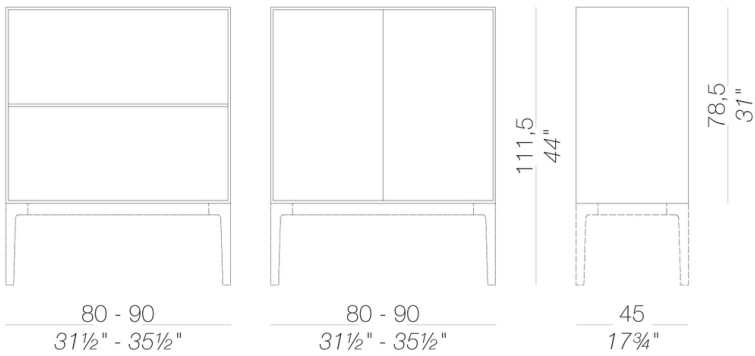

ADD S

Francesco Rota | 2016

telaio per seduta

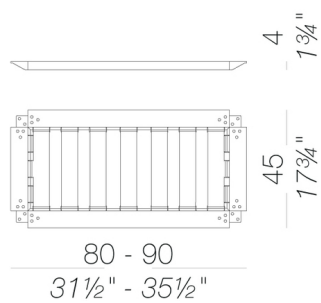

cuscino

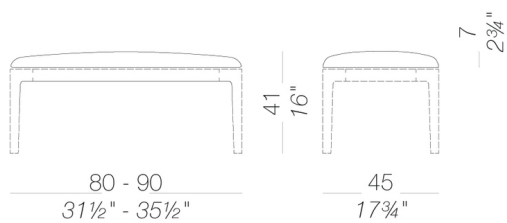

cassettiera su ruote

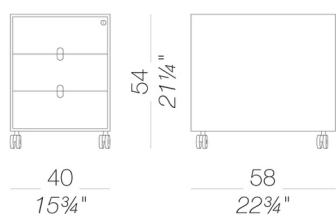

ADD S

Francesco Rota | 2016

struttura



verniciature a
polvere
nera
1 Colori



verniciature a
polvere
bianca
1 Colori

cassettiera su ruote



verniciature a
polvere
nera
1 Colori

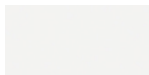

verniciature a
polvere
bianca
1 Colori

rivestimento cassette e ante

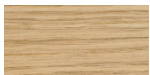

legno
rovere sbiancato
1 Colori

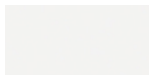

laccati
lacquered
2 Colori



tessuto
Hallingdal 65 - Cat.
C
58 Colori



tessuto
Canvas 2 - Cat. C
45 Colori



tessuto
Steelcut Trio 3 - Cat. D
54 Colori



tessuto
Remix 3 - Cat. C
72 Colori



tessuto
Clara 2 - Cat. C
24 Colori



tessuto
Fiord 2 - Cat. C
39 Colori

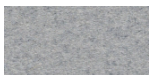

tessuto
Divina MD - Cat. D
27 Colori



tessuto
Divina Melange 3 -
Cat. D
38 Colori



tessuto
Tonica 2 - Cat. C
39 Colori



tessuto
Medley - Cat. A
37 Colori

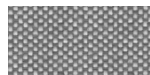

tessuto
Maya - Cat. A
43 Colori



tessuto
Jet - Cat. A
66 Colori

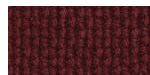

tessuto
Lapalma Smart -
Cat. C
18 Colori

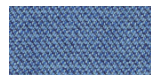

tessuto
Capture - Cat. B
43 Colori



tessuto
Crisp - Cat. B
40 Colori

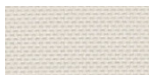

tessuto
Nattè - Cat. B
30 Colori

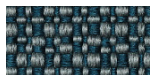

tessuto
Iris - Cat. B
24 Colori



tessuto
Steelcut 3 - Cat. D
40 Colori



ecopelle
GRIMM FR - Cat. A
32 Colori



ecopelle
Valencia - Cat. B
66 Colori

ADD S

Francesco Rota | 2016

schiene



verniciature a
polvere
nera
1 Colori

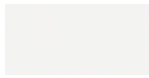

verniciature a
polvere
bianca
1 Colori



verniciature a
polvere
bianca
1 Colori



legno
rovere sbiancato
1 Colori

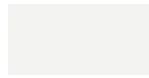

laccati
lacquered
2 Colori



metalli
lamiera forata
2 Colori

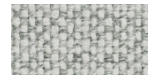

tessuto
Hallingdal 65 - Cat.
C
58 Colori



tessuto
Canvas 2 - Cat. C
45 Colori



tessuto
Steelcut Trio 3 - Cat.
D
54 Colori



tessuto
Remix 3 - Cat. C
72 Colori



tessuto
Clara 2 - Cat. C
24 Colori



tessuto
Fiord 2 - Cat. C
39 Colori



tessuto
Divina MD - Cat. D
27 Colori



tessuto
Divina Melange 3 -
Cat. D
38 Colori



tessuto
Tonica 2 - Cat. C
39 Colori

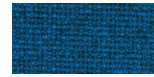

tessuto
Medley - Cat. A
37 Colori



tessuto
Jet - Cat. A
66 Colori

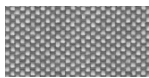

tessuto
Maya - Cat. A
43 Colori

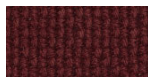

tessuto
Lapalma Smart -
Cat. C
18 Colori

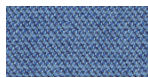

tessuto
Capture - Cat. B
43 Colori



tessuto
Crisp - Cat. B
40 Colori



tessuto
Nattè - Cat. B
30 Colori

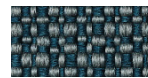

tessuto
Iris - Cat. B
24 Colori



tessuto
Steelcut 3 - Cat. D
40 Colori



ecopelle
Valencia - Cat. B
66 Colori



ecopelle
GRIMM FR - Cat. A
32 Colori

cuscino

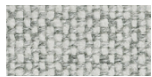

tessuto
Hallingdal 65 - Cat.
C
58 Colori



tessuto
Canvas 2 - Cat. C
45 Colori



tessuto
Steelcut Trio 3 - Cat.
D
54 Colori



tessuto
Remix 3 - Cat. C
72 Colori



tessuto
Fiord 2 - Cat. C
39 Colori



tessuto
Clara 2 - Cat. C
24 Colori



tessuto
Divina MD - Cat. D
27 Colori



tessuto
Divina Melange 3 -
Cat. D
38 Colori



tessuto
Tonica 2 - Cat. C
39 Colori



tessuto
Medley - Cat. A
37 Colori



tessuto
Jet - Cat. A
66 Colori

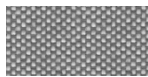

tessuto
Maya - Cat. A
43 Colori

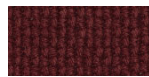

tessuto
Lapalma Smart -
Cat. C
18 Colori

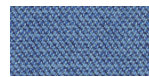

tessuto
Capture - Cat. B
43 Colori



tessuto
Crisp - Cat. B
40 Colori



tessuto
Nattè - Cat. B
30 Colori



ecopelle
GRIMM FR - Cat. A
32 Colori



tessuto
Iris - Cat. B
24 Colori



tessuto
Steelcut 3 - Cat. D
40 Colori



ecopelle
Valencia - Cat. B
66 Colori



tessuto
Grain - Cat. B
50 Colori



tessuto
Re-wool - Cat. C
21 Colori

piano



HPL 10 mm
HPL fenix
2 Colori



HPL 10 mm
HPL fenix
2 Colori

consultare la cartella materiali per la gamma colori, tessuti, pelli, ecopelli.

uso e manutenzione

Pulire tutte le parti in legno, cuoio, tessuto e metallo con un panno umido o con detergente liquido neutro diluito. Non usare prodotti a base alcolica, candeggina, solvente o prodotti abrasivi. Per sollevare e spostare il prodotto non afferrare solo il sedile, bensì afferrare saldamente la struttura. Il prodotto non deve essere sottoposto a carichi decentrati, è stato progettato per essere utilizzato in condizioni normali di appoggio (su 4 gambe o sulla base). L'azienda si solleva da ogni responsabilità per eventuali danni provocati su pavimenti delicati o teneri. Evitare l'uso improprio del prodotto: non salire sul prodotto coi piedi, né sul poggiatesta o sui braccioli. In particolar modo evitare oscillazioni che potrebbero pregiudicare il funzionamento e la sicurezza dell'utente. Il legno ed il cuoio sono, per loro natura, facilmente danneggiabili, alcune piccole impurità e imperfezioni rientrano negli standard di qualità accettati. Non esporre alle intemperie, agli agenti atmosferici, né a fonti di calore superiore a 40° C. I prodotti destinati a uso esterno subiscono comunque nel tempo l'azione degli agenti atmosferici. Eventuali alterazioni superficiali possono verificarsi a specifiche condizioni di esposizione di temperatura, umidità e salinità. Una corretta e frequente manutenzione e pulizia aumentano la durabilità del prodotto. Il prodotto, se esposto alla luce del sole, può essere soggetto a variazioni di colore. Interventi di manutenzione devono essere eseguiti da personale esperto. Smaltire l'imballo solo a completamento dell'assemblaggio, onde evitare lo smarrimento di eventuale ferramenta e componenti. Una volta smesso, il prodotto od i suoi componenti vanno conferiti ai sistemi pubblici di smaltimento secondo quanto previsto dalla legislazione in vigore.